

SFP 2.5Gb/s Bi-directional Transceiver BX 20Km (KW5620D-35) Hot Pluggable, LC, +3.3V 1310nm DFB-LD, DDMI

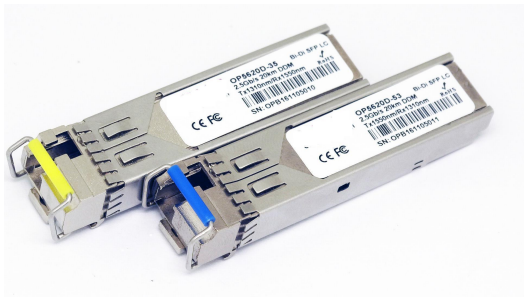

Features:

- ✧ Single Mode bi-directional Transmission
- ✧ SFP Multi-source Package with LC Receptacle
- ✧ Up to 2.5Gb/s Data Links
- ✧ Hot-Pluggable Capability
- ✧ Up to 20 km on 9/125µm SMF
- ✧ Single +3.3V Power Supply
- ✧ Built-in WDM
- ✧ Isolation > 30dB, Cross Talk < -45dB

- ✧ Monitoring Interface Compliant with SFF-8472
- ✧ Metal Enclosure, Excellent EMI & ESD Protection
- ✧ Compliant with Specifications for IEEE802.3Z
- ✧ Compliant with Bellcore TA-NWT-000983
- ✧ Eye Safety Designed to Meet Laser Class1, Compliant with IEC60825-1
- ✧ operating temperature range: 0°C to 70°C
- ✧ RoHS Compliant

Applications:

- ✧ SDH SMT-16
- ✧ SONET OC-48
- ✧ Fiber Channel
- ✧ WDM Application

Description:

KW5620D-35 Bi-Directional transceiver is a high performance, cost effective module ,which is compliant with LC Optics interface with built in WDM for Bi-Directional serial optical data communication applications. This module is designed for Single-Mode single fiber, operates at the normal wavelength of 1310/1550nm.

Standard AC coupled CML for high speed signal and LVTTTL control and monitor signals. The transmitter section incorporates DFB and driver IC with temperature compensation and automatic power control circuit, which make the transmitter section output power and Extinction ration stabled in operation temperature.

The receiver section incorporates an efficient InGaAs photodiode and transimpedance with AGC for wide dynamic range.

● Absolute Maximum Ratings

Parameter		Symbol	Min.	Typical	Max.	Unit
Storage Temperature		T _s	-40		+85	°C
Supply Voltage		V _{ccT, R}	-0.5		4	V
Relative Humidity		RH	0		85	%
Case Operating Temperature	Commercial	Top	0		70	°C

● Recommended Operating Environment:

Parameter		Symbol	Min.	Typical	Max.	Unit
Case operating Temperature	Commercial	T _c	-5		+70	°C

SFP 2.5Gb/s Bi-directional Transceiver BX 20Km (KW5620D-35) Hot Pluggable, LC, +3.3V 1310nm DFB-LD, DDMI

Supply Voltage	V _{CCT,R}	3.0		3.6	V
----------------	--------------------	-----	--	-----	---

● **Electrical Characteristics (T_{OP}, V_{CC} = 3.0 to 3.60 Volts)**

Parameter	Symbol	Min.	Typical	Max.	Unit	Note
Supply Voltage	V _{CC}	3.0	3.30	3.60	V	
Supply Current	I _{CC}		160	280	mA	
Inrush Current	I _{surge}			I _{CC} +30	mA	
Maximum Power	P _{max}			1.0	W	
Transmitter Section:						
Input differential impedance	R _{in}	90	100	110	Ω	1
Single ended data input swing	V _{in PP}	200		1200	mVp-p	
Transmit Disable Voltage	V _D	V _{CC} – 1.3		V _{CC}	V	2
Transmit Enable Voltage	V _{EN}	V _{EE}		V _{EE} + 0.8	V	
Transmit Disable Assert Time	T _{dessert}			10	us	
Receiver Section:						
Single ended data output swing	V _{out,pp}	300		1000	mv	3
Data output rise time	t _r			260	ps	4
Data output fall time	t _f			260	ps	4
LOS Fault	V _{losfault}	V _{CC} – 0.5		V _{CC,host}	V	5
LOS Normal	V _{los norm}	V _{EE}		V _{EE} +0.5	V	5
Power Supply Rejection	PSR	100			mVpp	6
Total Generated Transmitter Jitter (peak to peak)	J _{TXp-p}			0.07	UI	
Total Generated Transmitter Jitter (rms)	J _{TXrms}			0.007	UI	

Note:

1. AC coupled.
2. Or open circuit.
3. Into 100 ohm differential termination.
4. 20 – 80 %
5. LOS is LVTTTL. Logic 0 indicates normal operation; logic 1 indicates no signal detected.
6. All transceiver specifications are compliant with a power supply sinusoidal modulation of 20 Hz to 1.5MHz up to specified value applied through the power supply filtering network shown on page 23 of the Small Form-factor Pluggable (SFP) Transceiver Multi-Source Agreement (MSA), September 14, 2000.

● **Optical Parameters(T_{OP}, V_{CC} = 3.00 to 3.60 Volts)**

Parameter	Symbol	Min.	Typical	Max.	Unit	Note
Transmitter Section:						
Center Wavelength	λ _c	1270	1310	1360	nm	1
Spectral Width	σ			1	nm	
Optical Output Power	P _{out}	-5		0	dBm	2
Optical Rise/Fall Time	t _r / t _f			260	ps	3

SFP 2.5Gb/s Bi-directional Transceiver BX 20Km (KW5620D-35) Hot Pluggable, LC, +3.3V 1310nm DFB-LD, DDMI

Extinction Ratio	ER	8.2			dB	
Total Generated Transmitter Jitter (peak to peak)	J _{TXP-p}			0.07	UI	
Total Generated Transmitter Jitter (rms)	J _{TXrms}			0.007	UI	
Eye Mask for Optical Output	Compliant with Eye Mask Defined in IEEE 802.3 standard					
Relative Intensity Noise	RIN			-120	dB/Hz	
Receiver Section:						
Optical Input Wavelength		1520	1550	1580	nm	
Optical Input Power	P _{in}	-18		0	dBm	4.5
Receiver Reflectance		12			dB	
Receiver Overload	P _{ol}			-3	dBm	4.5
RX Sensitivity	Sen			-18	dBm	4.5
RX_LOS Assert	LOS _A	-32			dBm	
RX_LOS Deassert	LOS _D			-20	dBm	
RX_LOS Hysteresis	LOS _H	0.5		5	dB	
General Specifications						
Data Rate	BR	2125		2500	Mb/s	
Bit Error Rate	BER			10 ⁻¹²		
Max. Supported Link Length on 9/125μm SMF@2.5G	LMAX			20	km	6
Total System Budget	LB	13			dB	7

Note

1. Also specified to meet curves in FC-PI 13.0 Figures 18 and 19, which allow trade-off between wavelength spectral width.
2. Class 1 Laser Safety per FDA/CDRH and EN (IEC) 60825 regulations.
3. Unfiltered, 20-80%. Complies with IEEE 802.3 (Gig. E), FC 1x and 2x eye masks when filtered.
4. Measured with conformance signals defined in FC-PI 13.0 specifications.
5. Measured with PRBS 2⁷-1 at 10⁻¹² BER
6. Dispersion limited per FC-PI Rev. 13
7. Attenuation of 0.25 dB/km is used for the link length calculations. Distances are indicative only. Please refer to the Optical Specifications in Table IV to calculate a more accurate link budget based on specific conditions in your application.

● Digital Diagnostic Monitor Characteristics

The following digital diagnostic characteristics are defined over the Recommended Operating Environment unless otherwise specified. It is compliant to SFF8472 Rev10.2 with internal calibration mode. For external calibration mode please contact our sales staff..

Parameter	Symbol	Min.	Max.	Unit
Temperature monitor absolute error	DMI_Temp	-3	3	degC
Laser power monitor absolute error	DMI_TX	-3	3	dB
RX power monitor absolute error	DMI_RX	-3	3	dB
Supply voltage monitor absolute error	DMI_VCC	-0.1	0.1	V
Bias current monitor absolute error	DMI_Ibias	-10%	10%	mA

SFP 2.5Gb/s Bi-directional Transceiver BX 20Km (KW5620D-35) Hot Pluggable, LC, +3.3V 1310nm DFB-LD, DDMI

● **Block Diagram of Transceiver:**

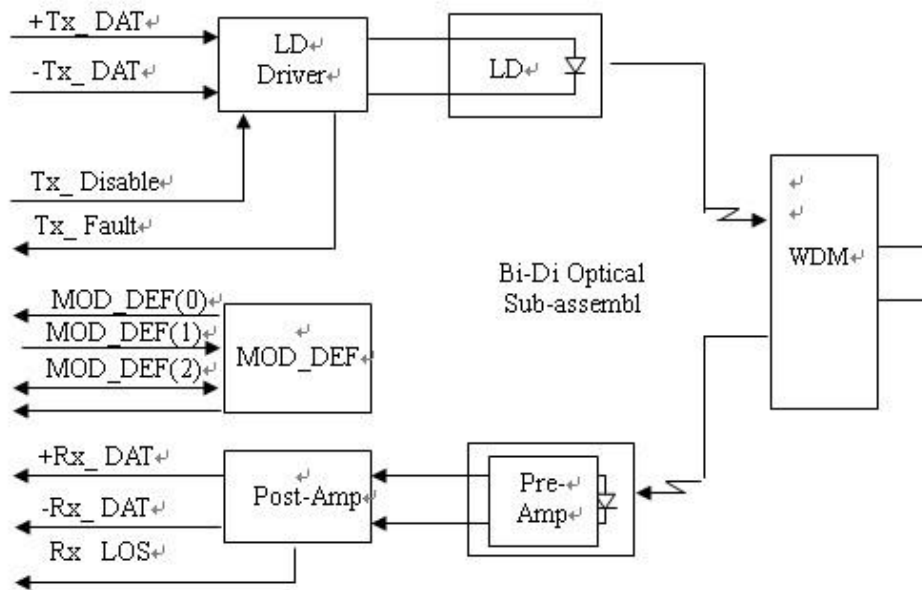

Figure1: Block Diagram

● **Pin Assignment:**

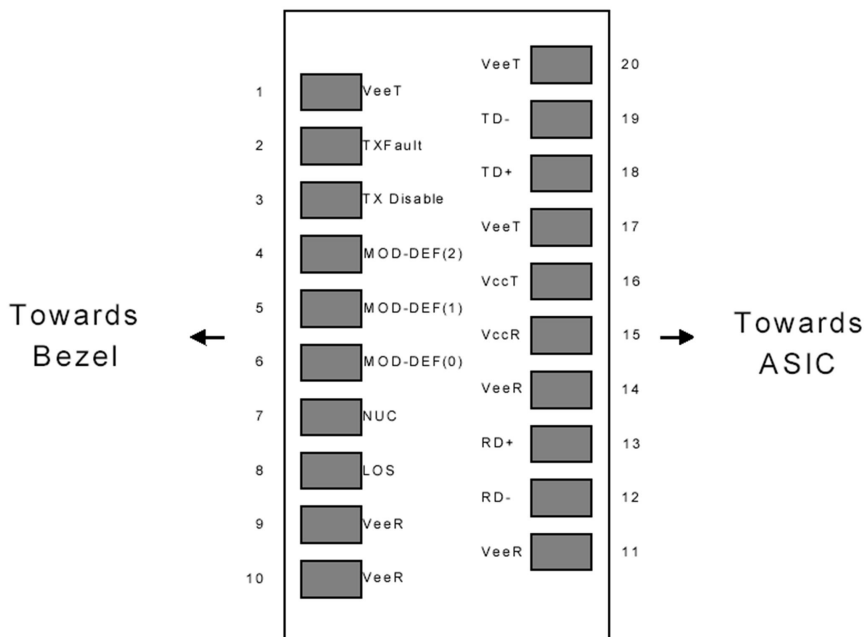

Figure2: Diagram of Host Board Connector Block Pin Numbers and Names

SFP 2.5Gb/s Bi-directional Transceiver BX 20Km (KW5620D-35) Hot Pluggable, LC, +3.3V 1310nm DFB-LD, DDMI

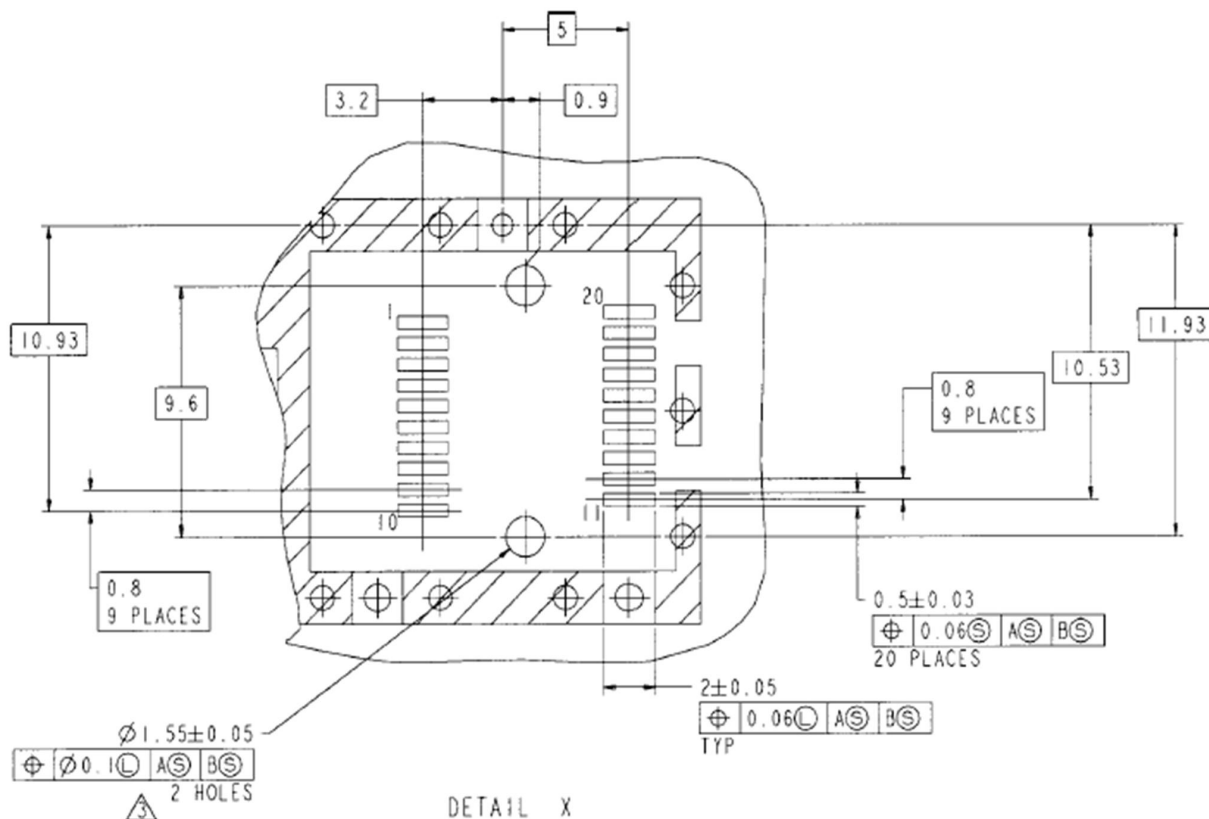

Figure 3: SFP Host Board Mechanical Layout

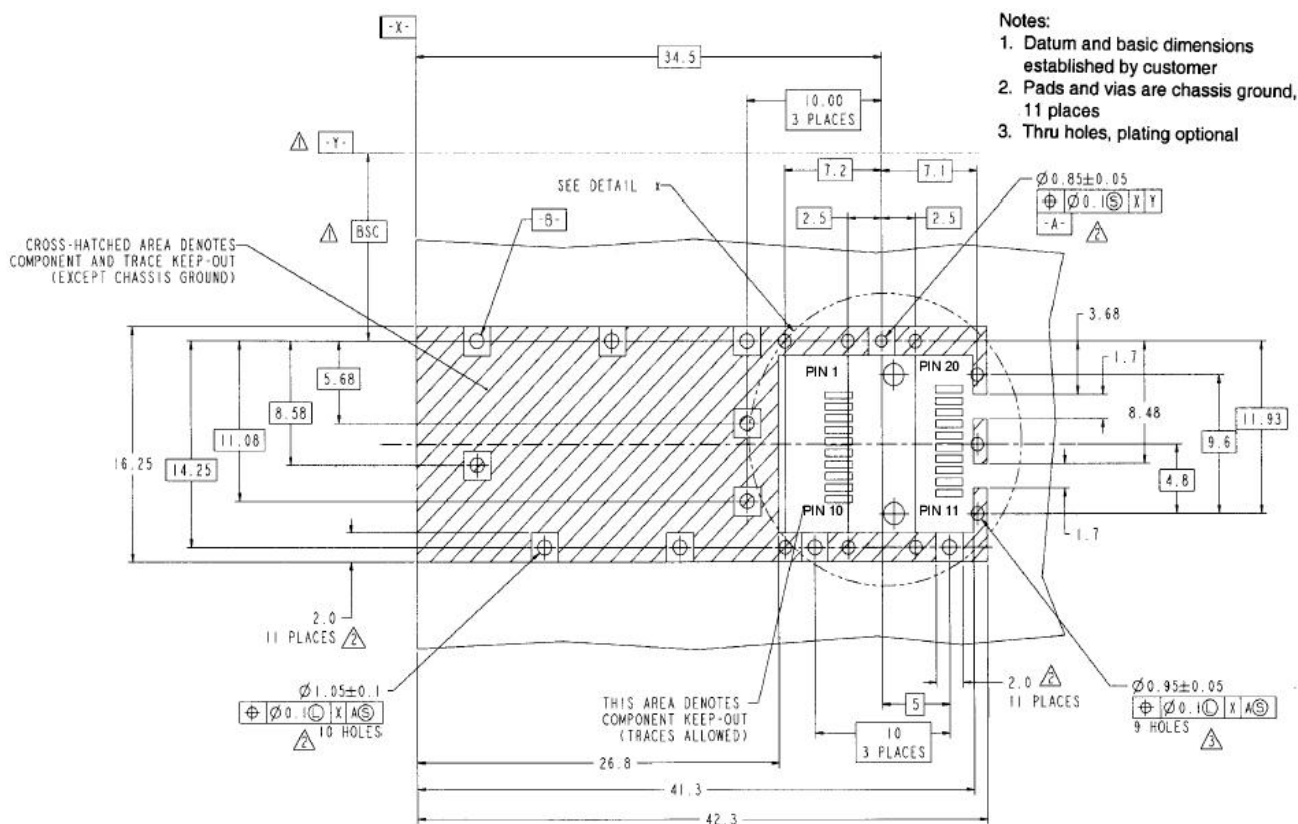

Figure 4: SFP Host Board Mechanical Layout(Cont)

SFP 2.5Gb/s Bi-directional Transceiver BX 20Km (KW5620D-35) Hot Pluggable, LC, +3.3V 1310nm DFB-LD, DDMI

● Pin Description:

Pin No	Name	Function	Plug Seq	Notes
1	VeeT	Transmitter Ground	1	1
2	TX Fault	Transmitter Fault Indication	3	
3	TX Disable	Transmitter Disable	3	2
4	MOD-DEF2	Module Definition	2	3
5	MOD-DEF1	Module Definition 1	3	3
6	MOD-DEF0	Module Definition 0	3	3
7	Rate Select	Not Connected	3	4
8	LOS	Loss of Signal	3	5
9	VeeR	Receiver Ground	1	1
10	VeeR	Receiver Ground	1	1
11	VeeR	Receiver Ground		1
12	RD-	Inv. Received Data Out	3	6
13	RD+	Received Data Out	3	6
14	VeeR	Receiver Ground	3	1
15	VccR	Receiver Power	2	1
16	VccT	Transmitter Power	2	
17	VeeT	Transmitter Ground	1	
18	TD+	Transmit Data In	3	6
19	TD-	Inv. Transmit In	3	6
20	VeeT	Transmitter Ground	1	

Notes:

1. Circuit ground is internally isolated from chassis ground.
2. Laser output disabled on TDIS >2.0V or open, enabled on TDIS <0.8V.
3. Should be pulled up with 4.7k - 10 kohms on host board to a voltage between 2.0V and 3.6V. MOD_DEF(0) pulls line low to indicate module is plugged in.
4. Rate select is not used
5. LOS is open collector output. Should be pulled up with 4.7k – 10 kohms on host board to a voltage between 2.0V and 3.6V. Logic 0 indicates normal operation; logic 1 indicates loss of signal.
6. AC Coupled

SFP 2.5Gb/s Bi-directional Transceiver BX 20Km (KW5620D-35) Hot Pluggable, LC, +3.3V 1310nm DFB-LD, DDMI

● **Recommended Circuit:**

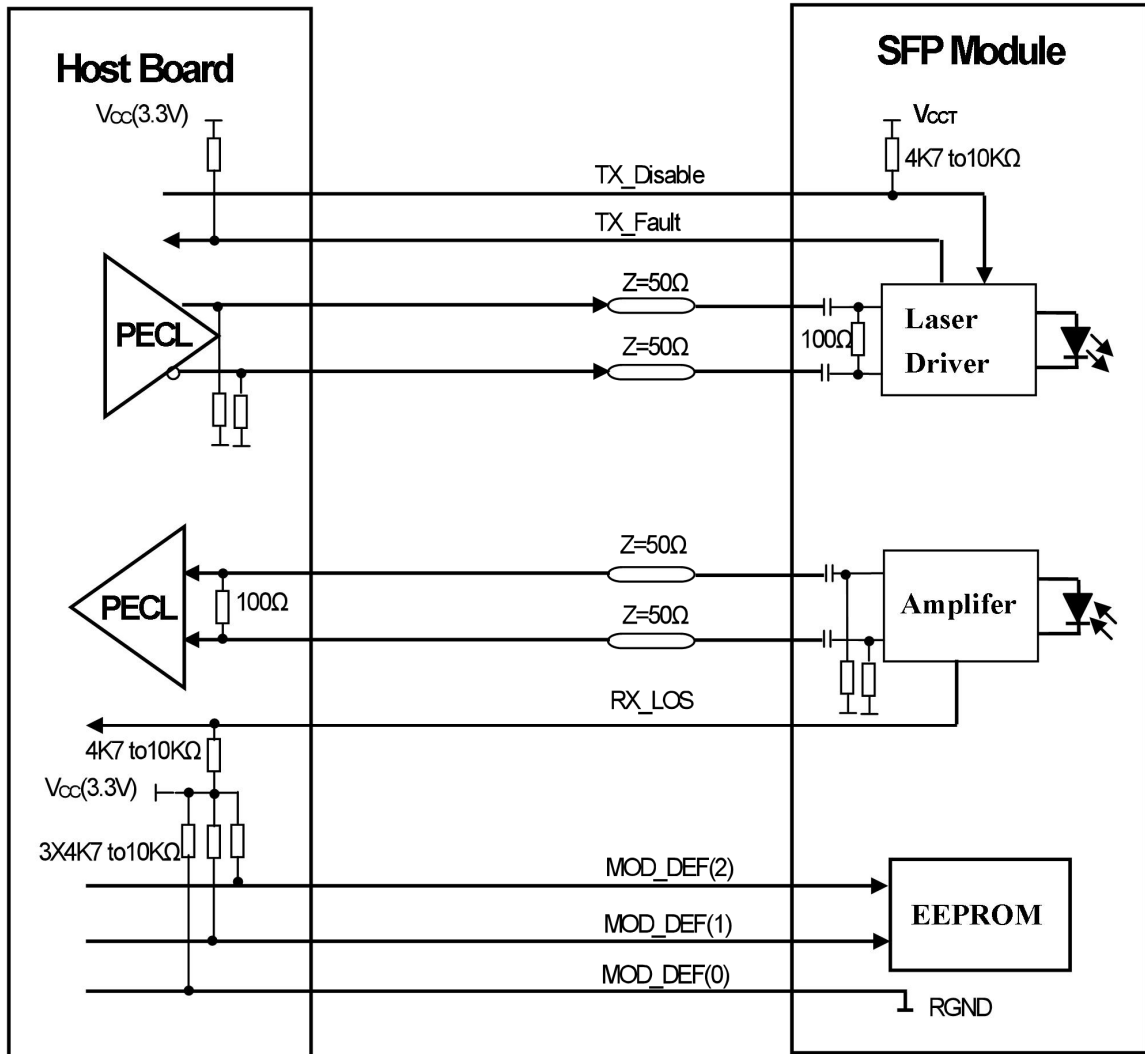

Figure 5: SFP Host Recommended Circuit

● **Serial ID Memory Contents:**

Data Address	Length (Byte)	Name of Length	Description and Contents
Base ID Fields			
0	1	Identifier	Type of Serial transceiver (03h=SFP)
1	1	Reserved	Extended identifier of type serial transceiver (04h)
2	1	Connector	Code of optical connector type (07=LC)
3-10	8	Transceiver	SONET
11	1	Encoding	SONET Scrambled
12	1	BR,Nominal	Nominal baud rate, unit of 100Mbps
13	1	Reserved	(0000h)
14	1	Length(9um,km)	Link length supported for 9/125um fiber, units of km

SFP 2.5Gb/s Bi-directional Transceiver BX 20Km (KW5620D-35)Hot Pluggable, LC, +3.3V 1310nm DFB-LD, DDMI

15	1	Length(9um)	Link length supported for 9/125um fiber, units of 100m
16	1	Length(50um)	Link length supported for 50/125um fiber, units of 10m
17	1	Length(62.5um)	Link length supported for 62.5/125um fiber, units of 10m
18	1	Length(Copper)	Link length supported for copper, units of meters
19	1	Reserved	
20-35	16	Vendor Name	SFP vendor name:
36	1	Reserved	
37-39	3	Vendor OUI	SFP transceiver vendor OUI ID
40-55	16	Vendor PN	Part Number: "KWXXXXXX"
56-59	4	Vendor rev	(ASCII)Revision level for part number
60-61	2	Wavelength	Laser wavelength
62	1	Reserved	
63	1	CCID	Least significant byte of sum of data in address 0-62
Extended ID Fields			
64-65	2	Option	Indicates which optical SFP signals are implemented(001Ah = LOS, TX_FAULT, TX_DISABLE all supported)
66	1	BR, max	Upper bit rate margin, units of %
67	1	BR, min	Lower bit rate margin, units of %
68-83	16	Vendor SN	Serial number (ASCII)
84-91	8	Date code	Manufacturing date code
92	1	Diagnostic Type	Diagnostics
93	1	Enhanced Options	Diagnostics
94	1	SFF-8472	Diagnostics
95	1	CCEX	Check code for the extended ID Fields (addresses 64 to 94)
Vendor Specific ID Fields			
96-127	32	Readable	Vendor specific data, read only

● **Diagnostics Memory Contents(A2h):**

Data Address	Length (Byte)	Name of Length	Description and Contents
Diagnostic and control/status fields			
0-39	40	A/W Thresholds	Diagnostic Flag Alarm and Warning Thresholds
40-55	16	Unallocated	
56-91	16	Ext Cal Constants	Diagnostic calibration constants for optional External Calibration
92-94	3	Unallocated	
95	1	CC_DMI	Check code for Base Diagnostic Fields (addresses 0 to 94)
96-105	10	Diagnostics	Diagnostic Monitor Data (internally or externally calibrated)
106-109	4	Unallocated	
110	1	Status/Control	Optional Status and Control Bits
111	1	Reserved	Reserved for SFF-8079

SFP 2.5Gb/s Bi-directional Transceiver BX 20Km (KW5620D-35) Hot Pluggable, LC, +3.3V 1310nm DFB-LD, DDMI

112-113	2	Alarm Flags	Diagnostic Alarm Flag Status Bits
114-115	2	Unallocated	
116-117	2	Warning Flags	Diagnostic Warning Flag Status Bits
118-119	2	Ext Status/Control	Extended module control and status bytes
General use fields			
120-127	8	Vendor Specific	Vendor specific memory addresses
128-247	120	User EEPROM	User writable non-volatile memory
248-255	8	Vendor Control	Vendor specific control addresses

● **Mechanical Dimensions:**

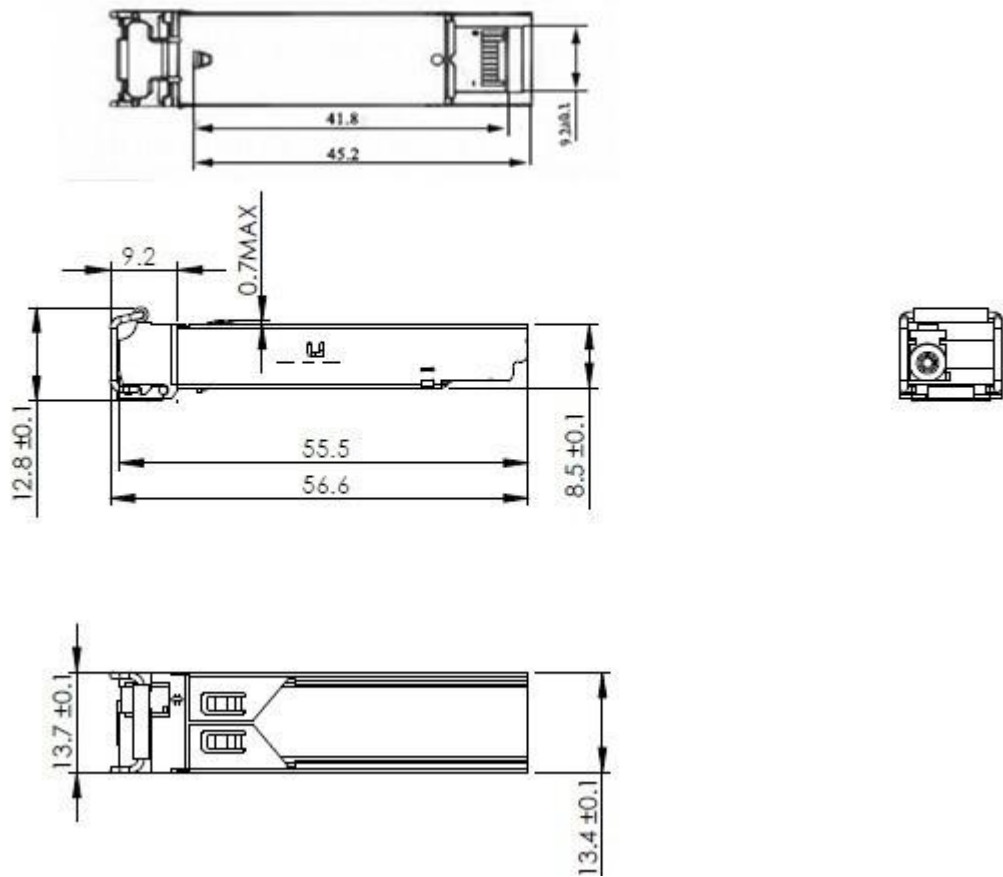

Figure 6. Mechanical Drawing