

SFP 1.25Gb/s Transceiver ZX 80Km (KW3480D

) Hot Pluggable, Duplex LC, +3.3V, 1550nm DFB-LD,
DDMI



- ✧ Duplex LC connector
- ✧ RoHS compliant and Lead Free
- ✧ Up to 80 km on 9/125µm SMF
- ✧ Single +3.3V Power Supply
- ✧ Monitoring Interface Compliant with SFF-8472
- ✧ Low power dissipation <1W typically
- ✧ Commercial operating temperature range: 0°C to 70°C

Features:

- ✧ Up to 1.25Gb/s Data Links
- ✧ Hot-Pluggable
- ✧ 1550nm DFB laser transmitter

Applications:

- ✧ Metro/Access Networks
- ✧ 1.25 Gb/s 1000Base-ZX Ethernet
- ✧ 1×Fiber Channel
- ✧ Other Optical Link

Description:

Kewei' K W 3480D Transceiver is a high performance, cost effective module which have a Duplex LCoptics interface. Standard AC coupled CML for high speed signal and LVTTTL control and monitor signals. The receiver section uses a PIN receiver and the transmitter uses 1550 nm DFB laser, up to 22dB link budge ensure this module 1000Base Ethernet 80Km application.

● Absolute Maximum Ratings

Parameter	Symbol	Min.	Typical	Max.	Unit
Storage Temperature	T _s	-40		+85	°C
Supply Voltage	V _{CC}	-0.5		4	V
Relative Humidity	RH	0		85	%

● Recommended Operating Environment:

Parameter	Symbol	Min.	Typical	Max.	Unit
Case operating Temperature	T _C	0		70	°C
Supply Voltage	V _{CC}	3.0	3.30	3.60	V
Supply Current	I _{CC}		160	280	mA
Inrush Current	I _{surge}			I _{CC} +30	mA
Maximum Power	P _{max}			1.0	W

SFP 1.25Gb/s Transceiver ZX 80Km (KW3480D

) Hot Pluggable, Duplex LC, +3.3V, 1550nm DFB-LD,

DDMI

● Electrical Characteristics (T_{OP} = T_c, VCC = 3.0 to 3.60 Volts)

Parameter	Symbol	Min.	Typical	Max.	Unit	Note
Transmitter Section:						
Input differential impedance	R _{in}	90	100	110		
Single ended data input swing	V _{in pp}	200		1200	mVp-p	
Transmit Disable Voltage	V _D	V _{CC} - 1.3		V _{CC}	V	2
Transmit Enable Voltage	V _{EN}	V _{ee}		V _{ee} + 0.8	V	
Transmit Disable Assert Time	T _{dessert}			10	us	
Receiver Section:						
Single ended data output swing	V _{out,pp}	300		1000	mv	3
Data output rise time	t _r			260	ps	4
Data output fall time	t _f			260	ps	4
LOS Fault	V _{losfault}	V _{CC} - 0.5		V _{CC_host}	V	5
LOS Normal	V _{los norm}	V _{ee}		V _{ee} +0.5	V	5
Power Supply Rejection	PSR	100			mVpp	6
Deterministic Jitter Contribution	RXΔDJ			51.7	ps	7
Total Jitter Contribution	RXΔTJ			122.4	ps	

Note:

1. AC coupled.
2. Or open circuit.
3. Into 100 ohm differential termination.
4. 20 – 80 %
5. LOS is LVTTTL. Logic 0 indicates normal operation; logic 1 indicates no signal detected.
6. All transceiver specifications are compliant with a power supply sinusoidal modulation of 20 Hz to 1.5MHz up to specified value applied through the power supply filtering network shown on page 23 of the Small Form-factor Pluggable (SFP) Transceiver Multi-Source Agreement (MSA), September 14, 2000.
7. Measured with DJ-free data input signal. In actual application, output DJ will be the sum of input DJ and . DJ.

● Optical Parameters(T_{OP} = T_c, VCC = 3.00 to 3.60 Volts)

Parameter	Symbol	Min.	Typical	Max.	Unit	Note
Transmitter Section:						
Center Wavelength	λ _c	1500	1550	1580	nm	1
Spectral Width(-20dB)	σ			1	nm	
Optical Output Power	P _{out}	-2		+3	dBm	2
Optical Rise/Fall Time	t _r / t _f			260	ps	3
Extinction Ratio	ER	9			dB	
Deterministic Jitter Contribution	TXΔDJ			56.5	ps	4
Total Jitter Contribution	TXΔTJ			119	ps	
Eye Mask for Optical Output	Compliant with Eye Mask Defined in IEEE 802.3 standard					
Receiver Section:						
Optical Input Wavelength		1270		1610	nm	
Optical Input Power	P _{in}	-24		-3	dBm	5.6
Receiver Overload	P _{ol}	-3			dBm	5.6

SFP 1.25Gb/s Transceiver ZX 80Km (KW3480D)
Hot Pluggable, Duplex LC, +3.3V, 1550nm DFB-LD,DDMI

RX Sensitivity	Sen			-24	dBm	5.6
RX_LOS Assert	LOS _A	-40			dBm	
RX_LOS Deassert	LOS _D			-25	dBm	
RX_LOS Hysteresis	LOS _H	0.5			dB	
General Specifications						
Data Rate	BR		1250		Mb/s	
Bit Error Rate	BER			10 ⁻¹²		
Max. Supported Link Length on 9/125µm SMF@1.25G	LMAX			80	km	7
Total System Budget	LB	22			dB	

Note

1. Also specified to meet curves in FC-PI 13.0 Figures 18 and 19, which allow trade-off between wavelength spectral width.
2. Class 1 Laser Safety per FDA/CDRH and EN (IEC) 60825 regulations.
3. Unfiltered, 20-80%. Complies with IEEE 802.3 (Gig. E), FC 1x and 2x eye masks when filtered.
4. Measured with DJ-free data input signal. In actual application, output DJ will be the sum of input DJ and . DJ.
5. Measured with conformance signals defined in FC-PI 13.0 specifications.
6. Measured with PRBS 2⁷ -1 at 10⁻¹² BER
7. Dispersion limited per FC-PI Rev. 13

● Pin Assignment:

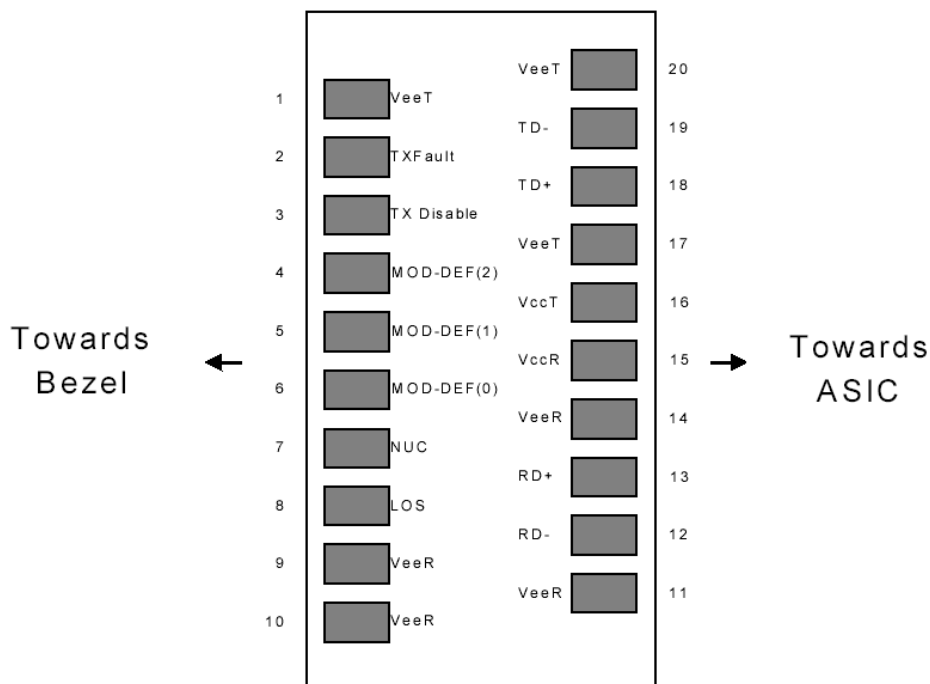

Diagram of Host Board Connector Block Pin Numbers and Names

● Pin Description:

Pin No	Name	Function	Plug Seq	Notes
1	VeeT	Transmitter Ground	1	1
2	TX Fault	Transmitter Fault Indication	3	
3	TX Disable	Transmitter Disable	3	2

SFP 1.25Gb/s Transceiver ZX 80Km (KW3480D)
Hot Pluggable, Duplex LC, +3.3V, 1550nm DFB-LD,DDMI

4	MOD-DEF2	Module Definition	2	3
5	MOD-DEF1	Module Definition 1	3	3
6	MOD-DEF0	Module Definition 0	3	3
7	Rate Select	Not Connected	3	4
8	LOS	Loss of Signal	3	5
9	VeeR	Receiver Ground	1	1
10	VeeR	Receiver Ground	1	1
11	VeeR	Receiver Ground		1
12	RD-	Inv. Received Data Out	3	6
13	RD+	Received Data Out	3	6
14	VeeR	Receiver Ground	3	1
15	VccR	Receiver Power	2	1
16	VccT	Transmitter Power	2	
17	VeeT	Transmitter Ground	1	
18	TD+	Transmit Data In	3	6
19	TD-	Inv. Transmit In	3	6
20	VeeT	Transmitter Ground	1	

Notes:

1. Circuit ground is internally isolated from chassis ground.
2. Laser output disabled on TDIS >2.0V or open, enabled on TDIS <0.8V.
3. Should be pulled up with 4.7k - 10 kohms on host board to a voltage between 2.0V and 3.6V. MOD_DEF(0) pulls line low to indicate module is plugged in.
4. Rate select is not used
5. LOS is open collector output. Should be pulled up with 4.7k – 10 kohms on host board to a voltage between 2.0V and 3.6V. Logic 0 indicates normal operation; logic 1 indicates loss of signal.
6. AC Coupled

● Recommended Circuit:

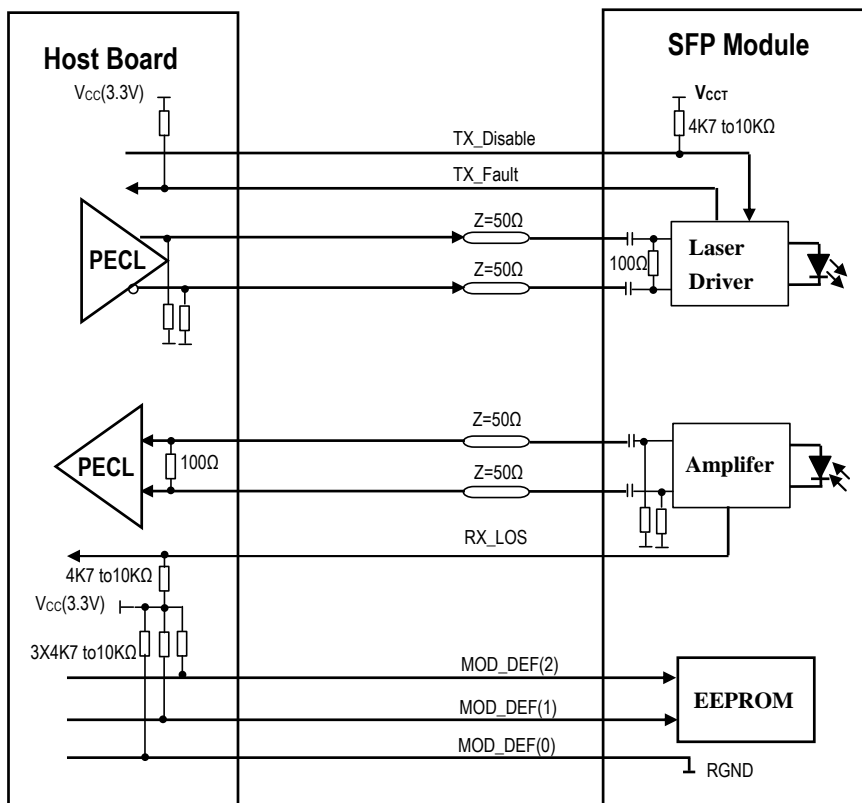

SFP Host Recommended Circuit

SFP 1.25Gb/s Transceiver ZX 80Km (KW3480D)
Hot Pluggable, Duplex LC, +3.3V, 1550nm DFB-LD,DDMI

● **Serial ID Memory Contents:**

Data Address	Length (Byte)	Name of Length	Description and Contents
Base ID Fields			
0	1	Identifier	Type of Serial transceiver (03h=SFP)
1	1	Reserved	Extended identifier of type serial transceiver (04h)
2	1	Connector	Code of optical connector type (07=LC)
3-10	8	Transceiver	
11	1	Encoding	NRZ(03h)
12	1	BR,Nominal	Nominal baud rate, unit of 100Mbps
13	1	Reserved	(0000h)
14	1	Length(9um,km)	Link length supported for 9/125um fiber, units of km
15	1	Length(9um)	Link length supported for 9/125um fiber, units of 100m
16	1	Length(50um)	Link length supported for 50/125um fiber, units of 10m
17	1	Length(62.5um)	Link length supported for 62.5/125um fiber, units of 10m
18	1	Length(Copper)	Link length supported for copper, units of meters
19	1	Reserved	
20-35	16	Vendor Name	SFP vendor name:
36	1	Reserved	
37-39	3	Vendor OUI	SFP transceiver vendor OUI ID
40-55	16	Vendor PN	Part Number: "KWxxxxx" (ASCII)
56-59	4	Vendor rev	Revision level for part number
60-61	2	Wavelength	Laser wavelength
62	1	Reserved	
63	1	CCID	Least significant byte of sum of data in address 0-62
Extended ID Fields			
64-65	2	Option	Indicates which optical SFP signals are implemented(001Ah = LOS, TX_FAULT, TX_DISABLE all supported)
66	1	BR, max	Upper bit rate margin, units of %
67	1	BR, min	Lower bit rate margin, units of %
68-83	16	Vendor SN	Serial number (ASCII)
84-91	8	Date code	Manufacturing date code
92	1	Diagnostic Type	Diagnostics
93	1	Enhanced Options	Diagnostics
94	1	SFF-8472	Diagnostics
95	1	CCEX	Check code for the extended ID Fields (addresses 64 to 94)
Vendor Specific ID Fields			
96-127	32	Readable	Vendor specific data, read only
128-255	128	Reserved	Reserved for SFF-8079

● **References**

1. IEEE Std 802.3, 2002 Edition, Clause 38, PMD Type 1000BASE-ZX.IEEE Standards Department, 2002.
2. "Fibre Channel Physical and Signaling Interface (FC-PH, FC-PH2, FC-PH3)".American National Standard for Information Systems.
3. "Fibre Channel Draft Physical Interface Specification (FC-PI 13.0)". American National

SFP 1.25Gb/s Transceiver ZX 80Km (KW3480D) Hot Pluggable, Duplex LC, +3.3V, 1550nm DFB-LD,DDMI

Standard for Information Systems.

- Small Form-factor Pluggable (SFP) Transceiver Multi-source Agreement (MSA) September 14, 2000.

● **Digital Diagnostic Monitor Characteristics**

Data Address	Parameter	Accuracy	Unit
96-97	Transceiver Internal Temperature	±3.0	°C
98-99	VCC3 Internal Supply Voltage	±5.0	%
100-101	Laser Bias Current	±10	%
102-103	Tx Output Power	±3.0	dBm
104-105	Rx Input Power	±3.0	dBm

● **Regulatory Compliance**

The KW3480D complies with international Electromagnetic Compatibility (EMC) and international safety requirements and standards (see details in Table following).

Electrostatic Discharge (ESD) to the Electrical Pins	MIL-STD-883E Method 3015.7	Class 1(>1000 V)
Electrostatic Discharge (ESD) to the Duplex LC Receptacle	IEC 61000-4-2 GR-1089-CORE	Compatible with standards
Electromagnetic Interference (EMI)	FCC Part 15 Class B EN55022 Class B (CISPR 22B) VCCI Class B	Compatible with standards
Laser Eye Safety	FDA 21CFR 1040.10 and 1040.11 EN60950, EN (IEC) 60825-1,2	Compatible with Class 1 laser product.

● **Mechanical Dimensions:**

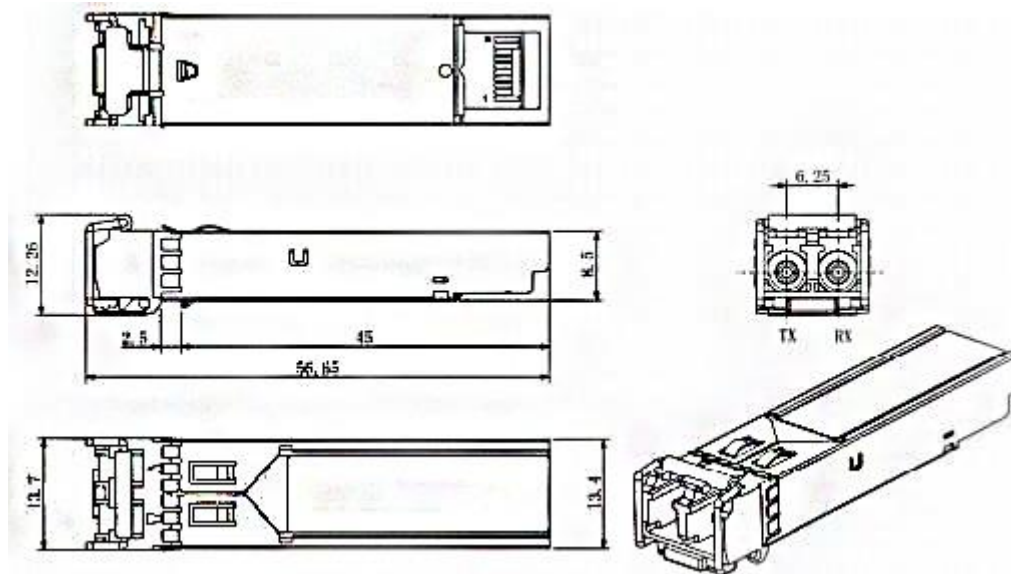

Mechanical Drawing

SFP 1.25Gb/s Transceiver ZX 80Km (KW3480D)
Hot Pluggable, Duplex LC, +3.3V, 1550nm DFB-LD,DDMI

KEWEI reserves the right to make changes to the products or information contained herein without notice. No liability is assumed as a result of their use or application. No rights under any patent accompany the sale of any such products or information.

Published by Kunshan Kewei Fiber Communications Equipment Co., Ltd.

Copyright © KEWEI

All Rights Reserved